

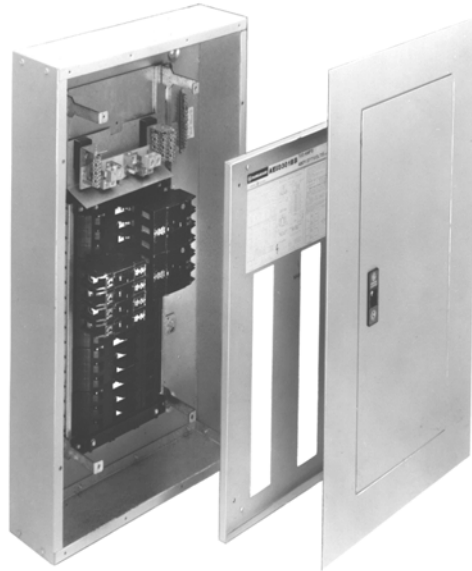

A Series® Lighting Panels
Panneaux d'éclairage A Series®

Rating Labels

Étiquettes



<p>INSTALLATION CONSULT INSTRUCTIONS NEMA PB 1.1 LOCATED IN CIRCUIT DIRECTORY ON FRONT DOOR BEFORE INSTALLING PANELBOARD. ORDER REPLACEMENT MANUAL FROM SUPPLIER</p>	<p>INSTALLATION AVANT D'INSTALLER LE PANNEAU, CONSULTER LA NOTICE NEMA PB 1.1 SITUÉE DANS LE PORTE-RÉPERTOIRE DE CIRCUITS, SUR LA PORTE DU PANNEAU. AU BESOIN, SE PROCURER LA NOTICE CHEZ SON DISTRIBUTEUR GE.</p>
<p>USE COPPER OR ALUMINUM WIRE</p> <ul style="list-style-type: none"> • USE 60° OR 75° C AMPACITY SIZED WIRE ON LINE AND NEUTRAL AND EQUIPMENT GROUND TERMINALS. • STANDARD WIRE SIZES LISTED BELOW MAY BE CHANGED BY USING ALTERNATE TERMINAL KITS. • REFER TO CIRCUIT BREAKERS FOR ALLOWABLE WIRE TEMPERATURE RATING, WIRE SIZE AND TIGHTENING TORQUE. 	<p>UTILISER DES FILS DE CUIVRE OU D'ALUMINUM</p> <ul style="list-style-type: none"> • UTILISER DES FILS AYANT UN COURANT ADMISSIBLE BASÉ SUR UNE TEMPÉRATURE DE SERVICE DE 60°C OU 75° POUR LES CONNEXIONS AUX BORNES DE PHASE ET NEUTRE. • LE CALIBRE DES FILS INDIQUÉ AU TABLEAU CI-DESSOUS PEUT VARIER SELON LA TROUSSE DE RACCORDEMENT UTILISÉE. • POUR LES CONNEXIONS AUX DISJONCTEURS, SUIVRE LES INDICATIONS FIGURANT SUR LE DISJONCTEUR EN CE QUI A TRAIT À LA TEMPÉRATURE DE SERVICE NOMINALE DES CONDUCTEURS, AU CALIBRE DES FILS ET AU COUPLE DE SERRAGE DES BORNES.
<p>NEUTRAL RATED FOR 200% PANELBOARD PHASE CURRENT USE COPPER WIRE ONLY AT NEUTRAL MAIN LUGS</p> <ul style="list-style-type: none"> • 125A (1) NEUTRAL CABLES 2/0 MCM MAX. • 225A (2) NEUTRAL CABLES 250 MCM MAX. • 400A (2) NEUTRAL CABLES 600 MCM MAX. • 600A (4) NEUTRAL CABLES 350 MCM MAX. <p>SUITABLE FOR NONLINEAR LOADS 200% RATED NEUTRAL ADDITIONAL "Y" LUGS PROVIDED FOR 200% NEUTRAL USE COPPER WIRE ONLY AT NEUTRAL MAIN LUGS</p>	<p>LA BARRE DE NEUTRE A UNE CAPACITÉ ASSIGNÉE DE 200% DU COURANT DE PHASE DU PANNEAU. N'UTILISER QUE DU FIL EN CUIVRE POUR LE RACCORDEMENT AUX COSSES DE LA BARRE DE NEUTRE</p> <ul style="list-style-type: none"> • 125A (1) CABLE 2/0 MCM MAX. • 225A (2) CABLES 250 MCM MAX. • 400A (2) CABLES 600 MCM MAX. • 600A (4) CABLES 350 MCM MAX. <p>POUR CHARGES NON LINÉAIRES NEUTRE D'UNE CAPACITÉ ASSIGNÉE DE 200% COSSES «Y» SUPPLÉMENTAIRES FOURNIES POUR NEUTRE 200% N'UTILISER QUE DU FIL EN CUIVRE POUR LE RACCORDEMENT AUX COSSES DE LA BARRE DE NEUTRE</p>
<p>SHORT CIRCUIT CURRENT RATING THE MAXIMUM SHORT CIRCUIT CURRENT RATING OF THIS PANELBOARD, IN RMS SYMMETRICAL AMPERES, IS EQUAL TO THE LOWEST CURRENT INTERRUPTING RATING OF ANY DEVICE INSTALLED, EXCEPT AS NOTED IN THE SERIES RATING LISTED IN THIS BOOKLET WITH INTEGRAL OR REMOTE MAIN CIRCUIT BREAKER OR FUSIBLE SWITCH INSTALLED AHEAD OF THIS PANELBOARD. DEVICES TO BE INSTALLED OR REPLACEMENT UNITS SHALL BE FROM THE SAME MANUFACTURER, OF THE SAME TYPE, AND HAVE EQUAL OR GREATER INTERRUPTING CAPACITY.</p>	<p>COURANT DE COURT-CIRCUIT ASSIGNÉ LE COURANT DE COURT-CIRCUIT MAXIMAL ASSIGNÉ DE CE PANNEAU, EN AMPÈRES SYMÉTRIQUES EFF., CORRESPOND AU PLUS FAIBLE POUVOIR DE COUPURE PARMİ TOUS LES DISPOSITIFS INSTALLÉS, SAUF INDICATION CONTRAIRE, DANS LA LISTE DES CARACTÉRISTIQUES SÉRIE CI-DESSOUS SI UN INTERRUPTEUR À FUSIBLES OU UN DISJONCTEUR PRINCIPAL, INCORPORÉ AU PANNEAU OU À DISTANCE, EST POSÉ EN AVAL DE CE PANNEAU. LES DISPOSITIFS AJOUTÉS OU DE RECHANGE DOIVENT PROVENIR DU MÊME FABRICANT, ÊTRE DU MÊME TYPE ET AVOIR UN POUVOIR DE COUPURE ÉQUIVALENT OU SUPÉRIEUR.</p>
<p>MAXIMUM CONTINUOUS LOADS ON MAIN OR BRANCH CIRCUITS NOT TO EXCEED 80% OF THE RATINGS OF THE LISTED CIRCUIT BREAKERS.</p>	<p>LA CHARGE CONTINUE MAXIMALE DES CIRCUITS PRINCIPAUX ET DE DÉRIVATION NE DOIT PAS EXCÉDER 80% DE LA CAPACITÉ ASSIGNÉE DES DISJONCTEURS UTILISÉS.</p>
<p>BRANCH BREAKER STRAPS SUITABLE FOR 180 A MAX AND 225A MAX FOR FB BREAKER PANELS AE LIGHTING CONTROL PANELBOARDS BREAKER STRAPS SUITABLE FOR 150A MAX</p>	<p>LES COURROIES DU DISJONCTEUR DE DÉRIVATION CONVIENNENT JUSQU'À UN MAXIMUM DE 180 AMPÈRES. ET 225A MAXIMUM POUR LES PANNEAUX DE CONCASSEUR DE FB. LE ONCASSEUR E ANELBOARDS E ONTROLE E ECLAIRAGE E E ANGLER ONVENABLE OR 150A AXIMUM</p>

TIGHTENING TORQUE / COUPLES DE SERRAGE							
APPLIES TO LINE, NEUTRAL AND EQUIPMENT GROUND TERMINAL POUR LES BORNES DE PHASE, DE NEUTRE ET DE M.A.L.T. DE L'APPAREILLAGE							
SLOTTED SCREW / VIS À FENTE				INTERNAL HEX / HEX. INTERNE			
AWG	LBS-INS		HEX SIZE	LBS-INS			
WIRE / FIL	MIN	MAX		MIN	MAX		
14-10	32	35	3 / 16	108	120		
8	36	40	1 / 4	180	200		
6-4	41	45	5 / 16	240	275		
3-2/0	45	50	3 / 8	330	375		
			1 / 2	450	500		
PRO-STOCK LUG KITS FOR A-SERIES LIGHTING PANELBOARDS / PRO-L'ERGOT DU STOCK EQUIPE POUR PANELBOARDS D'ECLAIRAGE D'UN-FEUILLETON							
	PRESSURE LUG KIT	WIRE RANGE AL/CU	CRIMP LUG KIT	WIRE RANGE AL/CU	CRIMP TOOL	PRESSURE LUG KIT	WIRE RANGE CU. ONLY
125A	MLA1	6-350	MLT1	4-300	HUBBELL	MLR1	4-350
225A	MLA2	1/0-250	MLT2	2/0 - 500	ANDERSON VC6 FOR ALL AL & UPTO	MLR2	1/0-600
400A	STANDARD - MLA41	4-600	MLT41	500-750 (CU ONLY)	500 MCM CU VC7 FOR 500-750 MCM CU.	MLR41	1/0-600
	OVERSIZE - MLA62	3/0 - 800 (MAIN) & 4-600 (NEUTRAL)			BURNDY TOOL TYPE Y644HS -UPTO #6-1000 KCMIL CU & #5-750 KCMIL AL.		
600A	STANDARD - MLA61	4-500				MLR61	1/0-600
				WIRE SIZE - Cu / Al			
NEUTRAL LUG Z Z NEUTRE D'ERGOT		LARGE HOLES GRANDS TROUS		2 / 0 - 14			
		SMALL HOLES PETITS TROUS		No.4 - 14			
ACCESSORIES / ACCESSOIRES							
FILLER		1" QB, QL, EY = TQLFP1			1- 3/8" QD, ED, SE = TEDFP1		
EQUIPMENT GROUND	MATERIAL	BONDED	EXTRUDED BONDED GROUND	EXTRUDED ISOLATED GROUND	INSULATED ISOLATED GROUND	MAIN LUG	
	METAL	TGL2	EGS12	-	-	-	
	ALUMINIUM	-	AEBG	AEIG	-	TGL2 #6-20	
	COPPER	TGC2	AEBGC	AEIGC	ASPGIBC	-	

DC RATED PANELBOARD / PANNEAU c.c.	
E PANEL. USE ONLY WITH GE CIRCUIT BREAKERS AS SHOWN IN THE TABLE BELOW N'UTILISER QU'AVEC LES DISJONCTEURS DE LA LISTE CI-DESSOUS	
IF BREAKER TRIPS HANDLE WILL BE IN INTERMEDIATE POSITION TO RESTORE POWER 1. MOVE HANDLE TO OFF POSITION 2. THEN MOVE HANDLE TO ON POSITION.	EN CAS DE DÉCLENCHEMENT DU DISJONCTEUR, LA MANETTE SE RETROUVERA EN POSITION INTERMÉDIAIRE. POUR RÉTABLIR LE COURANT: 1. METTRE LA MANETTE À LA POSITION «OFF». 2. METTRE ENSUITE LA MANETTE À LA POSITION «ON».
SHORT CIRCUIT CURRENT RATING / CAPACITÉ DE COURT-CIRCUIT ASSIGNÉE 10,000 AMPS, 250 V dc / 10 000A, 250 V c.c.	
TYPICAL DC-RATED BREAKERS / DISJONCTEURS POUR APPLICATIONS À C.C.	
MAIN BREAKER / DISJONCTEURS PRINCIPAUX TEY, TFJ, TJJ	BRANCH BREAKER / DISJONCTEUR DE DÉRIVATION TEY, TED4, TFJ

TORQUE VALUES FOR PANELBOARD HARDWARE / VALEURS DE COUPLE POUR LA QUINCAILLERIE DU PANNEAU	
SCREW SIZE	TORQUE (IN-LBS)
#4 STEEL	16
#10 PLASTIC	16
#8 CU/ AL/STEEL	24
#10-32 CU/ AL/STEEL	32
1/4-20 AL/<.150 THICK CU	44
1/4-20 .150 THICK CU	60
5/16-18 CU/ AL/STEEL	110
3/8-16 CU/AL/STEEL	220
1/2-13 CU/AL/STEEL	220

AD PANEL – USE ONLY WITH GE TED, THED, SE AND FB CIRCUIT BREAKER. #2/0 AWG MAX WIRE.					
PANNEAU AD – N'UTILISER QUE LES DISJONCTEURS GE DU TYPE TED, THED SE, FB. CALIBRE MAXIMAL DES FILS 2/0 AWG					
USE AF FRONTS WITH AB BOXES					
POUR LES BOÎTIERS AB, UTILISER LES PLAQUES AVANT AF					
IC RATING	MAIN / DISJ. PRINCIPAL		BRANCH / DÉRIVATIONS		
	TYPE	MAX. AMP	TYPE	POLES	AMP. RANGE
100,000 AMPERES @480VAC MAX	FCH	100	TED THED	2,3 3	15-100 20-100
	SEP	150	TED	2,3	15-50
			THED	3	150
	SFP	250	TED, THED	2,3	15-100
			TED, THED	3	150
			SFH, SFL	2,3	70-250
			TFJ	2,3	70-225
			SEH, SEL	2,3	15-150
	SGP	400	SEH, SEL	2,3	15-150
			SFH, SFL	2,3	70-250
	J OR R FUSE	100	TED	2,3	15-100
	J, R OR T FUSE	100	TED4, TED6 THED6		
	R FUSE	200	SED, SEH, SEL	2,3	15-150
		400	TED4, TED6 THED6	2,3	20-100
	J OR T FUSE		SED, SEH, SEL	2,3	15-150
600		SED, SEH, SEL	2,3	15-150	
65,000 AMPERES @ 480 VAC MAX	FCV	100	TED	2,3	15-100
	SEL	150	TED, THED	1, 2, 3	15-100
			TED, THED	3	110-150
	SFL	250	TED, THED	2,3	15-100
			TED, THED	2,3	110-150
			SFH	2,3	70-250
			SEH	2,3	15-150
	SGL	400	TFJ	2,3	70-225
			TED	2	15
			TFJ	2,3	70-225
SED, SEH			2,3	15-150	
35,000 AMPERES @ 480 VAC MAX	FCV	100	TED	2,3	15-100
			TED, THED	3	110-150
			TFJ	2,3	70-225
			SEH	2,3	15-150
25,000 AMPERES @ 480VAC MAX	SGH	600	SFH	2,3	70-250
			TED	2,3	15-100
			TED	1, 2, 3	15-100
			TED	1, 2, 3	50-150
100,000 AMPERES @ 120/240 VAC MAX	SEL	150	TED, THED	1	15-100
			SEH	2	15-150
			TED, THED	1, 2	15-100
			TED, THED	1	15-100
85,000 AMPERES @ 120/240 VAC MAX	SEL	150	TED	1	15-100
			THED	1	15-100
			SEH	1, 2	15-100
			SFH	250	15-100
65,000 AMPERES @ 120/240 VAC MAX	SEH	150	TED	1, 2	15-100
			THED	1, 2	15-100
			TFJ	2	70-225
			TFJ	2	70-225
42,000 AMPERES @ 120/240 VAC MAX	SEH	150	TED	1	15-100
			TED	1	15-100
30,000 AMPERES	VOLTS AC MAX	480	INTEGRAL MAIN MOLDED-CASE SWITCH	REMOTE MAIN	
			TJJY	TJJ/THJK 225A. MAX	TJJ/THJK 400A. MAX
22,000 AMPERES	480	600	TJJY	TFJ, TFK 225A. MAX	TFJ, TFK 400A. MAX
			TJJY	TFJ, TFK 400A. MAX	TFJ, TFK 400A. MAX
14,000 AMPERES	480	600	TEDY	TED 100A. MAX	TED 100A. MAX
			TFJY	TED4, THED4 150A MAX	TED4, THED4 150A MAX
			TEDY	TED 150A. MAX	TED 150A. MAX
			TFJY	TED6/THED6/THFK 150A MAX	TED6/THED6/THFK 150A MAX
				TFJ/TFK 225A. MAX.	TFJ/TFK 225A. MAX.

AD PANEL – USE ONLY WITH GE TED, THED, SE AND FB CIRCUIT BREAKER. #2/0 AWG MAXIMUM WIRE.

PANNEAU AD – N'UTILISER QUE LES DISJONCTEURS GE DU TYPE TED, THED, SE, FBSECTION DES MAXIMALE DES FILS 2/0 AWG

USE AF FRONTS WITH AB BOXES / POUR LES BOITIERS AB, UTILISER LES PLAQUES AVANT AF

LC RATING	MAIN / DISJ. PRINCIPAL		BRANCH / DÉRIVATIONS		
	TYPE	MAX. AMP	TYPE	POLES	AMP. RANGE
200,000 AMPERES @ 240 VAC MAX	FCL	100	FBV	2,3	15-100
			TED		
	FCH	100	TED	1,2,3	15-100
	SEP	150	TED	1,2,3	15-100
			THED	3	150
	R FUSE	100	FBV	2,3	15-100
		200	SED, SEH, SEL	2,3	15-150
	J OR T FUSE	400	SEH, SEL	2,3	15-150
			SFH, SFL	2,3	70-250
			FBV	2,3	15-100
	SFP	250	SEH, SEL	2,3	15-150
			SFH, SFL	2,3	70-250
			SEH, SEL	2,3	15-150
			TED	1,2,3	15-100
			FBV	2,3	15-100
	SGP	400	SEL, SEH	2,3	15-150
			TED, THED	2,3	150
			SEH, SEL	2,3	15-150
			TFJ	2,3	70-225
			SFH, SFL	2,3	70-250
		FBV	2,3	15-100	
100,000 AMPERES @ 240 VAC MAX	FCN	100	TED	1,2,3	15-100
	SEL	150	TED	1,2,3	15-100
			THED	3	150
			FBV	2,3	15-100
	SFL	250	TED, THED, FBV	2,3	15-100
225		TED, THED	2,3	150	
85,000 AMPERES @ 240 VAC MAX	FCV	100	TED	1,2,3	15-100
	SEL	150	TED	1,2,3	15-100
			THED	3	150
			FBV	2,3	15-100
	SGL	400	TED	2,3	15-150
			FBV	2,3	15-100
			TFJ	2,3	70-225
FBV			2,3	15-100	
65,000 AMPERES @ 240 VAC MAX	FCV	100	FBV	2,3	15-100
	SEH	150	TED	1,2,3	15-100
			TED	1,2,3	15-100
			FBV	2,3	110-150
	SFH	250	TED	1,2,3	15-100
			FBV	2,3	110-150
	THED	150	TED	2,3	110-150
	SGH	600	TED	1	15-30
				3	110-150
			TFJ	2,3	70-225
42,000 AMPERES @ 240 VAC MAX	FCS, SEH	150	TED	1,2,3	15-100
	THED	150	TED	2,3	15-150
	SGD SGH	225	TED	1	15-30
			TED	3	110-150
			TFJ	2,3	70-225
			TED	1	15-30
				3	110-150
	TJJ	600	TFJ	2,3	70-225
			TED	2,3	15-150
			TFJ	2,3	70-225
22,000 AMPERES @ 240 VAC MAX	TFJ, TJJ	225	TED	2,3	110-150
	SFH	250			
	TJJ, SGH	600	TED	3	110-150
	SFH	250	TED	2,3	110-150
150,000 AMPERES @ 277 VAC MAX	FCL	100	TED	1	15-50
			THED	1	15-30
	FCN	100	THED	1	15-30

AD PANEL – USE ONLY WITH GE TED, THED, SE AND FB CIRCUIT BREAKER. #2/0 AWG MAXIMUM WIRE.					
PANNEAU AD – N'UTILISER QUE LES DISJONCTEURS GE DU TYPE TED, THED, SE, FBSECTION DES MAXIMALE DES FILS 2/0 AWG					
USE AF FRONTS WITH AB BOXES / POUR LES BOITIERS AB, UTILISER LES PLAQUES AVANT AF					
I.C RATING	MAIN / DISJ. PRINCIPAL		BRANCH / DÉRIVATIONS		
	TYPE	MAX. AMP	TYPE	POLES	AMP. RANGE
100,000 AMPERES @ 277 VAC MAX	FCH	100	TED	1	15-50
	SEP	150	TED, THED	1	15-50
	J OR T FUSE	200	TED,	1	15-50
		400	THED	1	15-30
	R FUSE	200	TED, THED	1	15-50
	SFP	250	TED, THED	1	15-50
	J, R OR T FUSE	100	TED	1	15-50
65,000 AMPERES @ 277 VAC MAX	FCV	100	THED	1	15-30
	SEL	150	TED	1	15-100
	SFL	250	TED, THED	1	15-50
	SGL4	400	TED	1	15-50
			THED	1	15-30
25000 AMPERES @277 VAC MAX	FCS	100	TED	1	15-100
	SFH	250	TED	1	15-100
	SEH	150	TED	1	15-100
150,000 AMPERS @ 480VAC MAX	FCL	100	TED	2,3	15-100

AE PANEL – USE ONLY WITH GE TEY CIRCUIT BREAKER					
PANNEAU AE – N'UTILISER QUE LES DISJONCTEURS GE DU TYPE TEY					
USE AF FRONTS WITH AB BOXES					
POUR LES BOITIERS AB, UTILISER LES PLAQUES AVANT AF					
I.C RATING	MAIN / DISJ. PRINCIPAL		BRANCH / DÉRIVATIONS		
	VOLTS AC MAX.	INTEGRAL MAIN CASE SWITCH	MOLDED-	REMOTE MAIN	
100,000 AMPERES @ 120/240 VAC MAX	FCH	100	TEY	2, 3	15-100
			TED, THED	2,3	20-100
	SEL	150	TEY	1, 2	15-100
	SFL	250	TEY	1, 2	15-100
65,000 AMPERES @ 120/240 VAC MAX			TED, THED	1, 2	15-100
	SFH	150	TEY	1, 2	15-100
	SFH	250	TED, THED	1, 2	15-100
100,000 AMPERES @ 480V/277 VAC MAX			TFJ	2	70-225
	SEP	150	TEY	2, 3	15-100
65,000 AMPERES @ 480V/277 VAC MAX			TEY	2, 3	15-100
	SEL	150	TEY	2, 3	15-100
14,000	480		TFJY	TFJ, TFK 225A MAX.	
30,000	480		TJJY	TJJ, TJK 400A MAX.	

AE LIGHTING CONTROL PANELS – USE ONLY WITH GE TEYRC AND TEY CIRCUIT BREAKERS and THQB @ 240v max. only.					
LE CONTROLE D'ECLAIRAGE DE AEF LAMBRISÉ – N'UTILISER QUE LES DISJONCTEURS GE DU TYPE TEY					
USE AF FRONTS WITH AB BOXES					
POUR LES BOITIERS AB, UTILISER LES PLAQUES AVANT AF					
I.C RATING	MAIN / DISJ. PRINCIPAL		BRANCH / DÉRIVATIONS		
	TYPE	MAX. AMP	TYPE	POLES	AMP. RANGE
200,000 AMPERES @ 120/240 VAC MAX	SEP	150	TEYRC	1, 2	15- 30
	SFP	250	TEYRC	1, 2	15- 30
	SEL	150	TEYRC	1, 2	15- 30
100,000 AMPERES @ 120/240 VAC MAX	SFL	250	TEYRC	1, 2	15- 30
	J OR T FUSE	400	TEYRC	1, 2	15- 30
65,000 AMPERES @ 120/240 VAC MAX	SEL	150	TEYRC	1, 2	15- 30
	SFH	250	TED, THED	1, 2	15-100
			TFJ	2	15- 30
100,000 AMPERES @ 480V/277 VAC MAX	SEP	150	TEYRC	1, 2	15- 30
100,000 AMPERES @ 480V/277 VAC MAX	SFP	250	TEYRC	1,2	15- 30
	SEL	150	TEYRC	1,2	15- 30
65,000 AMPERES @ 480V / 277 VAC MAX	SFL	250	TEYRC	1,2	15-30
			TEYRC	1,2	15-30
I.C RATING	VOLTS AC MAX.	INTEGRAL MAIN CASE SWITCH	MOLDED-	REMOTE MAIN	
14,000	480		TFJY	TFJ, TFK 225A MAX.	
14,000	480		TJJY	TJJ, SGH, TJK 400A MAX.	

AE PANEL - USE ONLY WITH GE TEY CIRCUIT BREAKER					
PANNEAU AE - N'UTILISER QUE LES DISJONCTEURS GE DU TYPE TEY					
USE AF FRONTS WITH AB BOXES					
POUR LES BOITIERS AB, UTILISER LES PLAQUES AVANT AF					
I.C RATING	MAIN / DISJ. PRINCIPAL		BRANCH / DÉRIVATIONS		
	TYPE	MAX. AMP	TYPE	POLES	AMP. RANGE
200,000 @ 240 VAC MAX	FCL	100	TEY	1, 2, 3	15-100
	SEP	150	TEY	1, 2	15-100
	SFP	250	TEY	1, 2	15-100
100,000 AMPERES @ 240 VAC MAX	FCV	100	TEY	1, 2, 3	15-100
			TED	1, 2, 3	15-100
			THED	1, 2, 3	15-100
	SEL	150	TEY	1, 2, 3	15-100
			TED	1, 2, 3	15-100
			THED	3	150
SFL	250	TEY	1, 2, 3	15-100	
85,000 AMPERES @ 240VAC MAX	SGL	400	TEY	1, 2	15-100
				3	15
65,000 AMPERES @ 240VAC MAX	FCV	100	TEY	1, 2, 3	15-100
			TED	1, 2, 3	15-100
			TEY	1, 2, 3	15-100
100,000 AMPERES @ 277VAC MAX	FCH	100	TEY	1	15-100
			TED	1	15-100
			TEY	1	15-100
	SFP	250	TEY	1	15-100
			TED, THED	1	15-50
			SFL	250	TEY
	SEP	150			
	R FUSE	200	TEY	1	15-100
	J, T FUSE	600			
65,000 AMPERES @ 277VAC MAX	FCN	100	TEY, TED	1	15-100
	SEL	150	TEY	1	15-100
	SFL	250			
	SGL	400			20
25,000 AMPERES @ 277VAC MAX.	FCS	100	TEY	1	15-100
	SEH	150	TEY	1	15-100
	SFH	250	TEY	1	15-100
			TED, THED	1	15-100
100,000 AMPERES @ 480 VAC MAX	FCH	100	TEY	2, 3	15-100
			TED	2, 3	15-100
			THED	2, 3	20-100
	SFP	250	TEY	2, 3	15-100
			TED	2, 3	15-100
			THED	3	150
	J OR T FUSE	400	TFJ	2, 3	70-225
		TFJ	2, 3	70-225	
65,000 AMPERES @ 480 VAC MAX	FCN	100	TEY	2, 3	15-100
			TED	2, 3	15-100
			THED		
	SGL	400	TEY	3	15-50
			TEY	2	15
			TED	2, 3	150
	SFL	250	TEY	2, 3	15-100
			TED	2, 3	15-100
			THED	2, 3	110-150
			TFJ	2, 3	70-225
25,000 AMPERES @ 480 VAC MAX	FCS	100	TEY	2, 3	15-100
			TED		
	SEH	150	TEY	2, 3	15-100
	SFH	250	TED	1, 2, 3	15-100
		THED	3	150	
200,000 AMPERES @ 120/240 VAC MAX	SEP	150	TEY	1, 2	15-100
	SFP	250	TEY	1, 2	15-100

AL PANEL – USE ONLY WITH GE THQL, THHQL, TXQL CIRCUIT BREAKERS.						
Panneau AL – N'UTILISER QUE LES DISJONCTEURS GE DU TYPE THQL, THHQL OU TXQL						
USE AF FRONTS WITH AB BOXES / POUR LES BOITIERS AB, UTILISER LES PLAQUES AVANT AF						
I.C. RATING	MAIN / DISJ. PRINCIPAL		BRANCH / DÉRIVATIONS			
	TYPE	MAX. AMP	TYPE	POLES	AMP. RANGE	
100,000 AMPERES @ 120/240 VAC MAX	SEL	150	TQD, THQD	2	125-150	
			THQL, THHQL	1, 2	15-100	
			THQL-GF	1, 2	15-30	
			TXQL	1, 2	15-100	
			TQD, THQD	2	125-225	
			THQL	1	15-70	
	SFL	250	THQL	2	15-125	
			TXQL, THQL-GF	1, 2	15-30	
			THQL	1	15-70	
			THHQL	2	15-125	
			THQL-GF, TXQL	1, 2	15-30	
			THQL-GF	1, 2	15-30	
85,000 AMPERES @ 120/240 VAC MAX	SGL	400	THQL-GF	1, 2	15-30	
		600	THQL, THHQL	2	15-100	
65,000 AMPERES @ 120/240 VAC MAX	SEH	150	THQL, THHQL	2	110-125	
			THQL	2	15-125	
			TQD, THQD	2	125-150	
			TXQL, THQL, THHQL	1, 2	15-100	
			THQL-GF	1, 2	15-30	
			THQL-AF, THHQL-AF	1, 2	15-20	
	SFH	250	THQL	1	15-70	
			THHQL	2	15-125	
			TQD, THQD	2	125-225	
			THQL-GF	1, 2	15-30	
			THQL-AF, THHQL-AF	1, 2	15-20	
			THQL	1	15-70	
	SGH	600	THHQL	2	15-125	
			THQL-GF	1, 2	15-30	
			THQL-AF, THHQL-AF	1, 2	15-20	
			THQL	1	15-70	
			THHQL	2	15-125	
			THQL-GF	1, 2	15-30	
42,000 AMPERES @ 120/240 VAC MAX	THFK	225	THQL-GF			
			THQL-AF, THHQL-AF	1, 2	15-20	
	SFH	250	THQL, THHQL, THQL-GF	1, 2	15-30	
			THQL-AF, THHQL-AF	1, 2	15-20	
	SGH	600	THQL, THHQL, THQL-GF	1, 2	15-30	
			THQL-AF, THHQL-AF	2	15-20	
	T FUSE	600	THQL, THHQL	1	15-30	
			THQL-GF	1	15-30	
			THQL-AF, THHQL-AF	1	15-20	
			THQL, THHQL	1, 2, 3	15-100	
	22,000 AMPERES @ 120/240 VAC MAX	SGH,	600	THQL, THHQL	1, 2	15-30
				THQL-GF	1, 2	15-30
THQL, THHQL				2	110-125	
THQL-AF, THHQL-AF				1, 2	15-20	
THQL-WY				1, 2	15-30	
THQL, THHQL				1, 2	15-100	
TJJ		600	THQL, THHQL	1, 2	15-100	
TJD THQD		400	THQL, THHQL	1, 2, 3	15-100	
			THQL-GF, THQL-WY	1, 2	15-30	
		225	THQL	2	110-125	
			THQL-AF, THHQL-AF	2	15-20	
		TFJ	225	THQL, THHQL	1, 2	15-100
				THQL-GF	1, 2	15-30
SFH		250	THQL-AF, THHQL-AF	1, 2	15-20	
			THQL-GF, THQL-WY	1, 2	15-30	
			THQL-AF	2	15-20	
			THQL	2	15-100	
18,000 AMPERES @ 120/240 VAC MAX		SED	150	THQL	1	15-70
	THHQL			2	15-125	
	THQL-GF			1, 2	15-30	
	THQL-AF, THHQL-AF			2	15-20	
I.C. RATING	VOLTS AC MAX.	INTEGRAL MAIN MOLDED- CASE SWITCH		REMOTE MAIN		
	240	TQDY		THQD 225A MAX		
	240	TJDY		TJD 400A MAX		

AL PANEL - USE ONLY WITH GE THQL, THHQL, TXQL CIRCUIT BREAKERS.						
SER QUE LES DISJONCTEURS GE DU TYPE THQL, THHQL OU TXQL						
USE AF FRONTS WITH AB BOXES						
POUR LES BOITIERS AB, UTILISER LES PLAQUES AVANT AF						
I.C. RATING	MAIN / DISJ. PRINC.		BRANCH / DÉRIVATIONS			
	TYPE	MAX. AMP	TYPE	POLES	AMP. RANGE	
200,000 AMPERES @240VAC MAX	FCL, FCH	100	THQL	1	15-70	
			THHQL	2, 3	15-100	
			TXQL	2, 3	15-30	
	SEP	150	THQL, THHQL, TXQL	2, 3	15-100	
	SFP	250	THQL, THHQL	3	15-100	
	SGP	600	TQD, THQD	2, 3	125-225	
100,000 AMPERES @ 240 VAC MAX	FCV	100	THQL	1	15-70	
			THHQL	2, 3	15-30	
			TXQL	2,3	15-30	
	SEL	150	TQD, THQD	2, 3	125-150	
			THQL, THHQL, TXQL	2, 3	15-100	
			THQL, THHQL	2	110-125	
	SFL	250	TQD, THQD	2, 3	125-225	
			THQL, THHQL	2	15-125	
			THQL, THHQL	3	15-100	
	SGL	600	TXQL	2, 3	15-30	
	R FUSE	200	THQL, THHQL	3	15-100	
	J, T FUSE	400	THQL, THHQL	2, 3	15-100	
TQD			2	100-225		
			TQD	3	125-225	
85,000 AMPERES @ 240 VAC MAX	FCV	100	THQL	1	15-70	
			THHQL	2,3	15-30	
			TXQL	2,3	15-30	
SGL	600	THQL, THHQL	2, 3	15-100		
			TFJ	2,3	70-225	
65,000 AMPERES @ 240 VAC MAX	FCV	100	THQL	1	15-70	
			THHQL	2, 3	15-100	
	TEY	100	THQL, THHQL	1, 2, 3	15-100	
	SEH	150	THQL, THHQL	2	110-125	
	SEL	150	TQD, THQD	2, 3	125-150	
			THQL, THHQL	2, 3	15-100	
	SFH	250	TQD, THQD	2, 3	125-225	
			THQL	2	15-125	
SGH	600	THHQL	3	15-100		
		THQL	2	15-125		
			THHQL	3	15-100	
42,000 AMPERES @ 240 VAC MAX	FCS	100	THQL, THHQL	2, 3	15-100	
	T	600	THQL	2	15-125	
	FUSE		THHQL	3	15-100	
22,000 AMPERES @ 240 VAC MAX	FCS	100	THQL, THHQL	2, 3	15-100	
	THHQL	100	THQL	2	15-100	
			THQL-WV	2	15-30	
	TFJ	225	TQD	2,3	100-225	
	TJD	400	THQL	3	15-100	
			TQD	2, 3	100-225	
	SGH	600	THQL	3	15-100	
			TQD	2, 3	100-225	
THQL-WV			2	15-30		
18,000 AMPERES @ 240 VAC MAX	FCS	100	THQL, THHQL	2, 3	15-100	
	SED	150	THQL	2	15-125	
			THHQL	3	15-100	
200,000 AMPERES @ 120/240 VAC MAX	FCL, FCH	100	TXQL	1	15-30	
	SEP	150	THQL, THHQL, TXQL	1, 2	15-100	
	SFP	250	THQL-GF	1, 2	15-30	
			THQL, THHQL	1, 2	15-70	
				THQL-GF	1, 2	15-20
	R FUSE	200	THQL			
	J, T FUSE	400	THHQL	1, 2	15-100	
SGP	600	THQL	1	15-70		
		THHQL	2	15-125		
			THQL-GF	1, 2	15-30	

AQ PANEL – USE ONLY WITH GE THQB, THHQB, TXQB, TQD AND THQD CIRCUIT BREAKERS.					
PANNEAU AQ – UTILISER SEULEMENT LES DISJONCTEURS GE MODÈLE THQB, THHQB TXQB TQD OU THQD					
USE AF FRONTS WITH AB BOXES					
UTILISER LES PANNEAUX AVANT AF AVEC LES BOITIERS AB					
IC RATING	MAIN		BRANCH		
	TYPE	MAX. AMP	TYPE	POLES	AMP. RANGE
100,000 AMPERES @ 120/240 VAC MAX	FCV	100	THQB	1	15-20
			THHQB	2,3	15-100
			TXQB	1	15-30
			THQB-GF	2	
	SEL	150	TQD, THQD	2	125-150
			THQB, THHQB	1,2	15-100
			TXQB	1,2	15-100
			THQB-GF	1,2	15-30
	SFL	250	THQB	1	15-70
			THHQB	2	15-125
			TXQB, THQB-GF	1,2	15-30
	R FUSE J OR T FUSE	200	THQB	1,2	15-100
400		THHQB			
SGL	600	THQB	1	15-70	
		THHQB	2	15-125	
		TXQB	1,2	15-30	
85,000 AMPERES @ 120/240 VAC MAX	FCV	100	THQB	1	15-20
			THHQB	2,3	15-100
			TXQB	1	15-30
			THQB-GF	2	
SGL	600	THQB-GF	1,2	15-30	
		THQB-GF	2	15-30	
65,000 AMPERES @ 120/240 VAC MAX	FCV	100	THQB	1	15-70
			THHQB	2,3	15-100
	TEY	100	THQB	1,2	15-100
			TQD, THQD	2	125-150
	SEH	150	THQB, THHQB	1,2	15-100
			TXQB	1,2	15-100
			THQB-GF	1,2	15-30
			THQB-AF, THHQB-AF	1,2	15-20
	SFH	250	THQB	1	15-70
			THHQB	2	15-125
			TQD, THQD	2	125-225
	SGH	600	THQB	1	15-70
			THHQB	2	15-125
			THQB-GF	1,2	15-30
			THQB-AF, THHQB-AF	1,2	15-20
	T FUSE	600	THHQB	1	15-70
42,000 AMPERES @ 120/240 VAC MAX	FCS	100	THQB-GF	2	15-70
			THQB	1	15-70
	TJJ	600	THHQB	2,3	15-100
			THQB	1,2	15-30
	SFH	250	THQB, THHQB, THQB-GF	1,2	15-30
			THQB-AF, THHQB-AF	1,2	15-20
	SGH	600	THQB, THHQB, THQB-GF	1,2	15-30
			THQB-AF, THHQB-AF	1,2	15-20
	T FUSE	600	THQB, THHQB	1	15-30
			THQB-GF	1	15-30
THQB-AF, THHQB-AF			1	15-20	
22,000 AMPERES @ 120/240 VAC MAX	FCS	100	THQB-GF	2	15-70
			THQB	1	15-70
	THHQB	100	THHQB	2,3	15-100
			THQB	1	15-70
	THHQB	125	THQB	2	15-100
			THQB	1	15-70
			THQB-GF, THQB-WY	1,2	15-30
	TJD THQD	400 225	THQB-AF	1,2	15-20
			THQB, THHQB	1,2,3	15-100
	TFJ	225	THQB-GF, THQB-WY	1,2	15-30
			THQB-AF, THHQB-AF	2	15-20
			THQB, THHQB	1,2	15-100
	SFH	250	THQB-GF	1,2	15-30
			THQB-AF, THHQB-AF	2	15-20
			THQB-GF, THQB-WY	1,2	15-30
	SGH	600	THQB-AF	2	15-20
			THQB, THHQB	1,2,3	15-100
			THQB-GF, THQB-WY	1,2	15-30
THQB-AF, THHQB-AF			2	15-20	
18,000 AMPERES @ 120/240 VAC MAX	FCS	100	TQD	2,3	100-225
			THQB-GF	2	15-70
			THQB	1	15-70
			THHQB	2,3	15-100
IC RATING	VOLTS AC MAX	INTEGRAL MAIN MOLDED-CASESWITCH		REMOTE MAIN	
14,000	240	TQDY		THQD 225A MAX	
22,000	240	TJDY		TJD 400A MAX	

AQ PANEL - USE ONLY WITH GE THQB, THHQB, TXQB, TQD AND THQD CIRCUIT BREAKERS.							
PANNEAU AQ - N'UTILISER QUE LES DISJONCTEURS GE DU TYPE THQB, THHQB, TXQB, TQD OU THQD							
USE AF FRONTS WITH AB BOXES							
POUR LES BOITIERS AB, UTILISER LES PLAQUES AVANT AF							
I.C. RATING	MAIN / DISJ. PRINC.		BRANCH / DÉRIVATIONS				
	TYPE	MAX. AMP	TYPE	POLES	AMP. RANGE		
200,000 AMPERES @ 240VAC MAX	SEP	150	THQB, THHQB, TXQB	2,3	15-100		
			TQD, THQD	2,3	125-150		
	SFL	250	THQB, THHQB, TXQB	2,3	15-100		
			THQB, THHQB	2	15-125		
			THQB, THHQB	3	15-100		
			TQD, THQD	2,3	125-225		
	100,000 AMPERES @ 240VAC MAX	SGP	600	THQB, THHQB	2	15-100	
				SEL	150	THQB, THHQB	2,3
		SFL	250	TXQB	2,3	15-100	
				TQD, THQD	2,3	125-150	
TQD, THQD				2,3	125-225		
THQB, THHQB				2	15-125		
THQB, THHQB				3	15-100		
TXQB				2,3	15-30		
R FUSE				200	THQB, THHQB	2,3	15-100
J or T FUSE				400	THQB, THHQB	2,3	15-100
65,000 AMPERES @ 240VAC	SGL	600	TQD	2	100-225		
			THQD	3	125-225		
	TEY	100	THQB, THHQB	3	15-100		
			SEL	150	THQB, THHQB	1,2,3	15-100
	SFH	250	TQD, THQD	2	15-100		
			THQB	2,3	125-225		
	42,000 AMPERES @ 240VAC MAX	SFH	250	THQB	2	15-125	
				THHQB	3	15-100	
		T FUSE	600	THQB	2	15-125	
				THHQB	3	15-100	
22,000 AMPERES @ 240VAC MAX		THHQB	100	THQB	2	15-100	
				THQB-WY	2	15-30	
		TJD	400	THQB	3	15-100	
				THQB-GF	1, 2	15-30	
	TQD, THQD			2,3	100-225		
	THQB-AF			1,2	15-20		
	SGH	600	THQB	3	15-100		
			THQB-WY	2	15-30		
			TQD, THQD	2,3	100-225		
			THQB, THHQB	1,2	15-100		
THQL-GF			1,2	15-30			
TXQB			1,2	15-100			
200,000 AMPERES @ 120/240 VAC MAX	SEP	150	THQB, THHQB	1, 2	15-70		
			THQB-GF	1,2	15-30		
	SFP	250	THQB, THHQB	1,2	15-100		
			TXQB	1,2	15-30		
			THQB-GF	1,2	15-20		
	R FUSE	200	THQB	1	15-70		
			J, T FUSE	400	THQB, THHQB	1,2	15-100
	SGP	600	THQB, THHQB	1	15-70		
			THQB, THHQB	2	15-125		
			THQB-GF	1,2	15-30		

AEC COLUMN PANEL - USE ONLY WITH GE TEY CIRCUIT BREAKERS.					
LE PANNEAU DE COLONNE DE COMISSARIAT A L'ENERGIE ATOMIQUE - UTILISE SEULEMENT AVEC LES DISJONCTEURS DE TEY DE GE					
USE AF FRONTS WITH AB BOXES					
UTILISER LES DEVANTS DE AF AVEC LES BOITES D'ABDOMINAL					
I.C. RATING	MAIN / DISJ. PRINC.		BRANCH / DÉRIVATIONS		
	TYPE	MAX. AMP	TYPE	POLES	AMP. RANGE
65,000 AMPERES @ 240VAC	SEH, SFH	150	TEY	1, 2, 3	15-100
65,000 AMPERES @ 480Y/277VAC	SEL	150	TEY	2, 3	15-100

AQC COLUMN PANEL – USE ONLY WITH GE THQB CIRCUIT BREAKERS.					
LE PANNEAU DE COLONNE DE AQC – UTILISE SEULEMENT AVEC LES DISJONCTEURS DE THQB DE GE					
USE AF FRONTS WITH AB BOXES					
UTILISER LES DEVANTS DE AF AVEC LES BOITES D'ABDOMINAL					
I.C RATING	MAIN / DISJ. PRINC.		BRANCH / DÉRIVATIONS		
	TYPE	MAX. AMP	TYPE	POLES	AMP. RANGE
22,000 AMPERES @ 240VAC MAX	THHQB	100	THQB	2	15-100
			THQB-WY	2	15-30
			THQB	3	15-100
	TJD	225	THQB-GF	1, 2	15-30
			TQD, THQD	2, 3	100-225
			THQB-AF	1, 2	15-20
65,000 AMPERES @ 240VAC	SEL	150	THQB, THHQB	2	15-100
	SFH	225	THQB	2	15-125
22,000 AMPERES @ 120/240VAC	THHQB	100	THHQB	3	15-100
			THQB	1	15-70
			THQB	2	15-100
	THHQB	125	THQB	1	15-70
			THQB	2	15-100
			THQB-GF, THQB-WY	1, 2	15-30
	TJD	400	THQB, THHQB	1, 2, 3	15-100
			THQB-AF	1, 2	15-20
	THQD	225	THQB-GF, THQB-WY	1, 2	15-30
			THQB-AF, THHQB-AF	2	15-20
	TFJ	225	THQB, THHQB	1, 2	15-100
			THQB-GF	1, 2	15-30
			THQB-AF, THHQB-AF	2	15-20
	SFH	225	THQB-GF, THQB-WY	1, 2	15-30
			THQB-AF	2	15-20
65,000 AMPERES @ 120/240VAC	TEY	100	THQB	1, 2	15-100
	SEH	150	TQD, THQD	2	125-150
			THQB, THHQB	1, 2	15-100
			TXQB	1, 2	15-100
			THQB-GF	1, 2	15-30
			THQB-AF, THHQB-AF	1, 2	15-20
			THQB	1	15-70
	SFH	225	THHQB	2	15-125
			TQD, THQD	2	125-225

ALC COLUMN PANEL – USE ONLY WITH GE THQL CIRCUIT BREAKERS.					
LE PANNEAU DE COLONNE DE ALC – UTILISE SEULEMENT AVEC LES DISJONCTEURS DE THQL DE GE					
USE AF FRONTS WITH AB BOXES					
UTILISER LES DEVANTS DE AF AVEC LES BOITES D'ABDOMINAL					
I.C RATING	MAIN / DISJ. PRINC.		BRANCH / DÉRIVATIONS		
	TYPE	MAX. AMP	TYPE	POLES	AMP. RANGE
65,000 AMPERES @ 240VAC	TEY	100	THQL, THHQL	1, 2, 3	15-100
	SEH	150	THQL, THHQL	2	110-125
			TQD, THQD	2, 3	125-150
			THQL, THHQL	2, 3	15-100
	SFH	225	TQD, THQD	2, 3	125-225
			THQL	2	15-125
THHQL			3	15-100	
22,000 AMPERES @ 240VAC	THHQL	100	THQL	2	15-100
TFJ	225	TQD	2, 3	100-225	
85,000 AMPERES @ 120/240VAC	SFL	225	THQL-GF	1, 2	15-30
			THQL, THHQL	2	15-100
65,000 AMPERES @ 120/240VAC	SEH	150	THQL, THHQL	2	110-125
			THQL	2	15-125
			TQD, THQD	2	125-150
			TXQL, THQL, THHQL	1, 2	15-100
			THQL-GF	1, 2	15-30
			THQL-AF, THHQL-AF	1, 2	15-20
	SFH	225	THQL	1	15-70
			THHQL	2	15-125
			TQD, THQD	2	125-225
	THQD	225	THQL-GF	1, 2	15-30
			THQL-AF, THHQL-AF	1, 2	15-20
			THQL	2	110-125
	TFJ	225	THQL-AF, THHQL-AF	2	15-20
			THQL, THHQL	1, 2	15-100
			THQL-GF	1, 2	15-30
SFH	250	THQL-AF, THHQL-AF	1, 2	15-20	
		THQL-GF	1, 2	15-30	
		THQL	2	15-100	
THQL-AF	2	15-20			

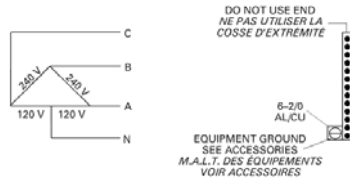
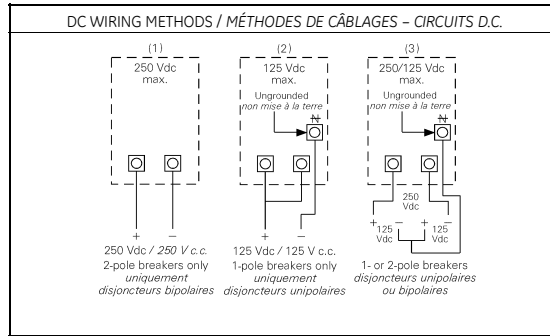

Alternate Voltage Rating: 240/120 VAC, 3-Phase 4-Wire Delta High Leg
Use only Circuit Breakers rated 240VAC on the B-Phase High Leg
Conversion Kits for adding 3-Pole Breakers
ABHBQ for AQ/AE Panels
ABHBL for AL Panels

Alterner le Classement de Tension: 240/120 VAC, 3-Introduire le Delta à 4 fils Haute Jambe
Utiliser seulement des Disjoncteurs ont évalué 240 VAC sur la B-PHASE l'Haute Jambe
La conversion Equipe pour ajouter Concasseurs de 3 Polonais
ABHBQ pour les Panneaux d'AQ/AE
ABHBL pour les Panneaux d'AL

Other Optional Kits:

ASP25AD65KA for changing AD panels to above 25KAIC rating
ASPSERENT for converting a non Service Entrance panel to Service Entrance, requires a bonding kit
Bonding Kits : 343L886G16 for Split & Load End Neutrals
343L886G13 for 225A Horizontal Neutrals
ASP225HNCP – 225A Horizontal Neutral to convert 3W to 4W
ASPHNCPSENOT 125/225A Horiz. Neutral conversion from Service Entrance to Non-Service Entrance
ASPHNCPSE 125/225A Horiz. Neutral to convert from Non-Service Entrance to Service Entrance.

Les autres Trousses Facultatives :

ASP25AD65KA pour changer de panneaux d'ANNONCE à au-dessus de 25KAIC classement
ASPSERENT pour convertir un non-Livraisons lambrise aux Livraisons, exige une trousse de formation du lien affectif
Adhérer les Trousses : 343L886G16 pour la Division & le Chargement Termine Neutre
343L886G13 pour 225A Horizontal Neutre
ASP225HNCP – 225A Horizontal Neutre pour convertir 3W à 4W
ASPHNCPSENOT 125/225A conversion Neutre Horizontale Des Livraisons à non-Livraisons
ASPHNCPSE 125/225A Horiz. Neutre pour convertir de non-Livraisons aux Livraisons

Wiring Diagram / Schéma unifiliare

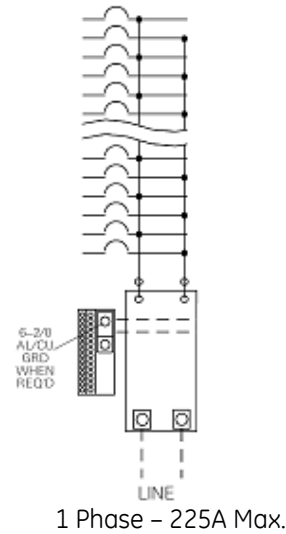
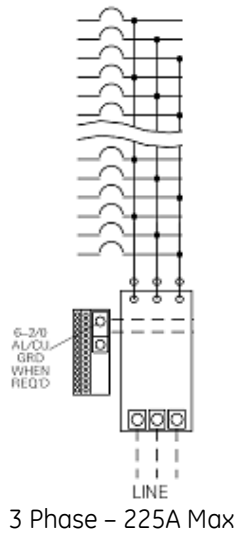

USE COPPER OR ALUMINUM WIRE

USE 60° C OR 75° C AMPACITY SIZED WIRE ON LINE AND NEUTRAL AND EQUIPMENT GROUND TERMINALS, EXCEPT AS NOTED BELOW

- REFER TO CIRCUIT BREAKERS FOR ALLOWABLE WIRE TEMPERATURE RATING, WIRE SIZE AND TIGHTENING TORQUE, EXCEPT AS NOTED BELOW.
 - USE #1 AWG. MAXIMUM, 75° C WIRE FOR 90A AND 100A HORIZONTAL MOUNTED Q-LINE BREAKERS ONLY.
 - USE #3 AWG. MAXIMUM 75° C, COPPER ONLY WIRE FOR 90-100A Q-LINE BREAKER & TEY MAIN BREAKERS HORIZONTALLY MOUNTED IN A 7 5/8" WIDE BOX
 - USE #3 AWG, MAXIMUM 60° C, COPPER ONLY WIRE FOR TEY 80A, MAX. HORIZONTALLY MOUNTED BRANCH BREAKERS.

LE CUIVRE D'USAGE OU LE FIL D'ALUMINIUM

L'USAGE 60° C OU 75° AMPACITY DE C A CALIBRE LE FIL CONNECTEE ET NEUTRE ET TERMINAUX DE SOL D'EQUIPEMENT, SAUF COMME REPUTE AU DESSOUS

- Se REFERER AUX DISJONCTEURS POUR LE CLASSEMENT DE TEMPERATURE DE FIL ADMISSIBLE, A LA TAILLE DE FIL ET A RESSERRER LE MOMENT DE TORSION, SAUF COMME REPUTE AU DESSOUS
 - L'USAGE #1 AWG. LE MAXIMUM, 75°e FIL DE C POUR L'HORIZONTALE DE 90A ET 100A A MONTE LES CONCASSEURS DE Q-LIGNE SEULEMENT.
 - L'USAGE #3 AWG. LE MAXIMUM 75°e C, LE CUIVRE SEULEMENT FIL POUR 90-100A CONCASSEUR DE Q-LIGNE & TEY LES CONCASSEURS PRINCIPAUX ONT MONTE HORIZONTALEMENT DANS UN 7 5/8" LA BOITE LARGE
 - L'USAGE #3 AWG, LE MAXIMUM 60°e C, LE CUIVRE SEULEMENT FIL POUR TEY 80A, LE MAXIMUM. LES CONCASSEURS HORIZONTALEMENT DE BRANCHE MONTES.

Wiring Diagram / Schéma unifiliare

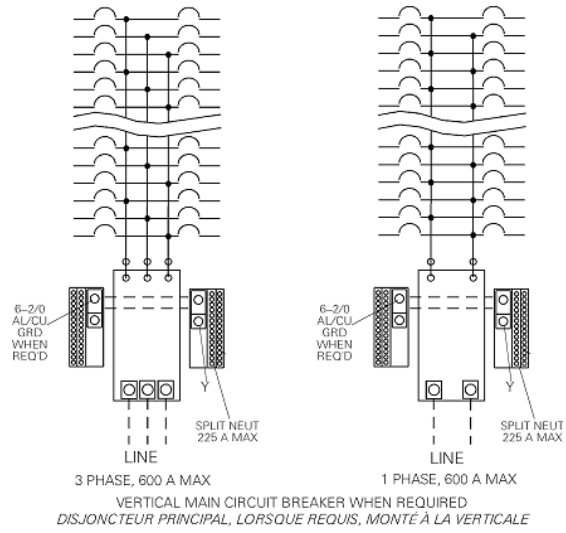
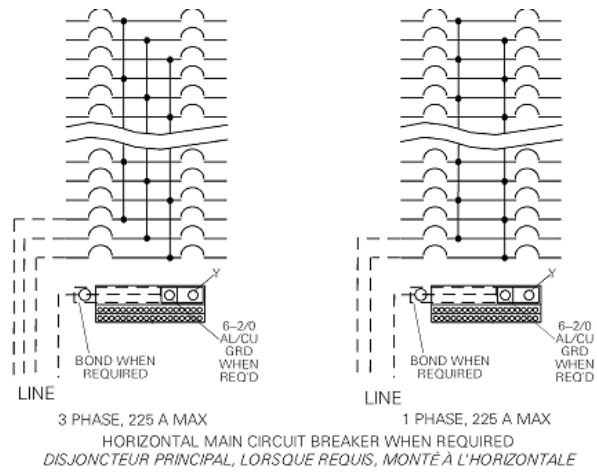

Wiring Diagram / Schéma unifiliare

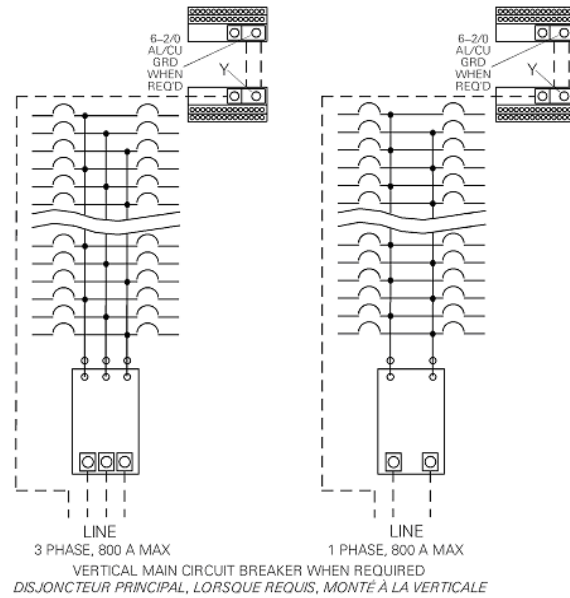
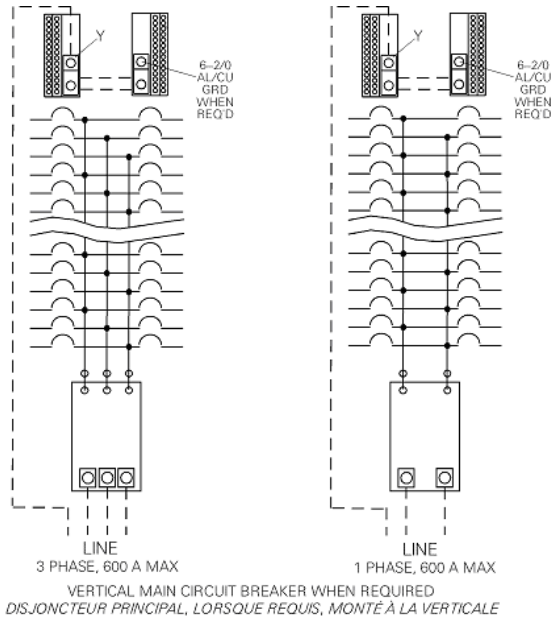

Wiring Diagram / Schéma unifiliare

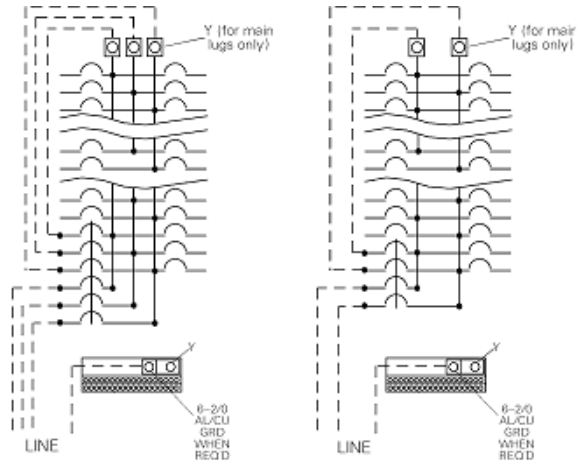

3 PHASE, 225 A MAX 1 PHASE, 225 A MAX
 HORIZONTAL MAIN CIRCUIT BREAKER WHEN REQUIRED
 DISJONCTEUR PRINCIPAL, LORSQUE REQUIS, MONTE À L'HORIZONTALE

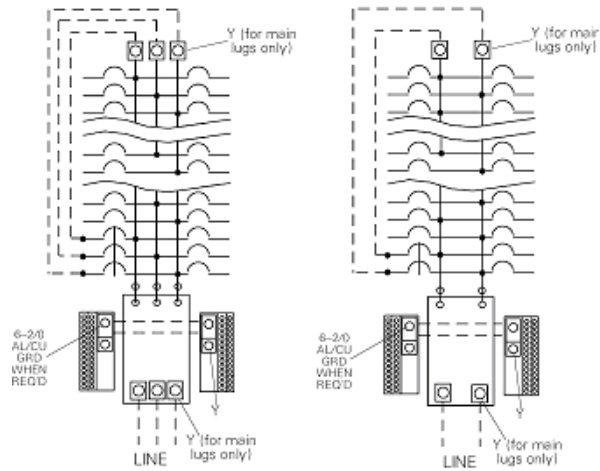

3 PHASE, 800 A MAX. 1 PHASE, 800 A MAX.
 MAIN LUGS ONLY OR VERTICAL MAIN CIRCUIT BREAKER
 COSSE PRINCIPAL SEULEMENT OU AVEC DISJONCTEUR MONTE À LA VERTICAL

Wiring Diagram / Schéma unifiliare

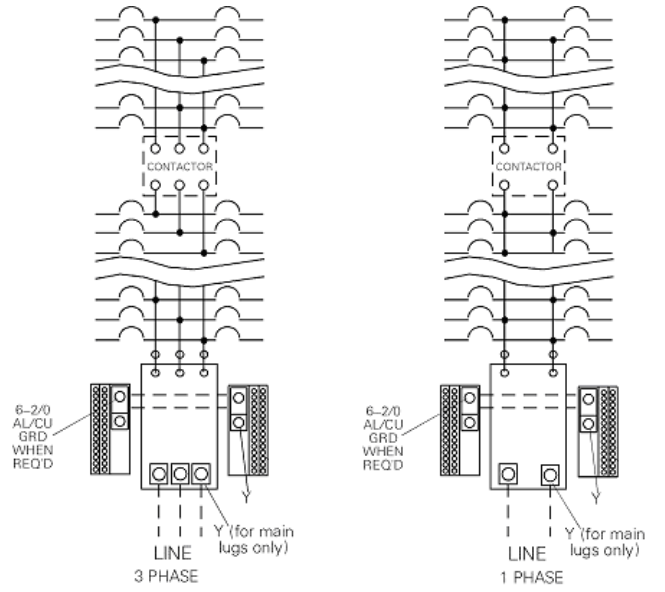

MAIN LUGS OR VERTICAL MAIN CIRCUIT BREAKER
 COSSES PRINCIPALES SEULEMENT OU AVEC DISJONCTEUR MONTE À LA VERTICALE

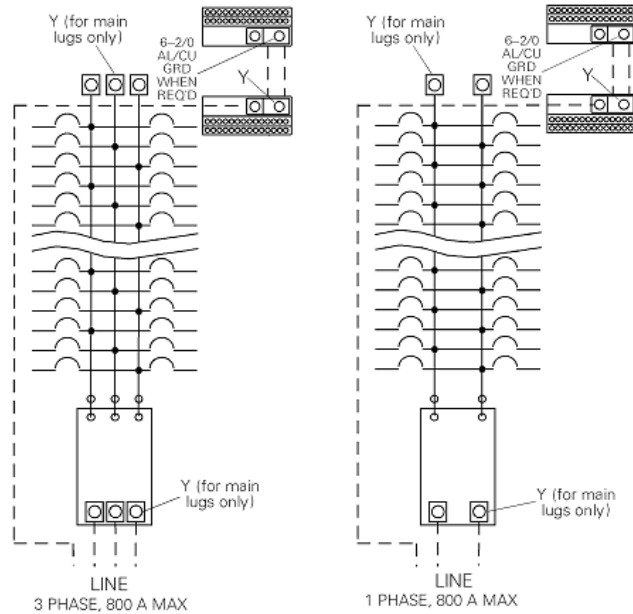

3 PHASE, 800 A MAX
 1 PHASE, 800 A MAX
 VERTICAL MAIN CIRCUIT BREAKER WHEN REQUIRED
 DISJONCTEUR PRINCIPAL, LORSQUE REQUIS, MONTE À LA VERTICALE

Wiring Diagram / Schéma unifilaire

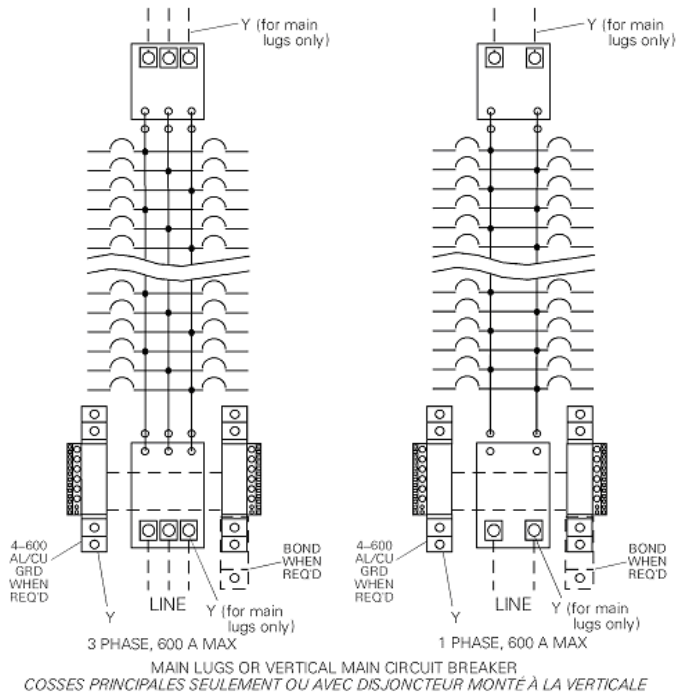
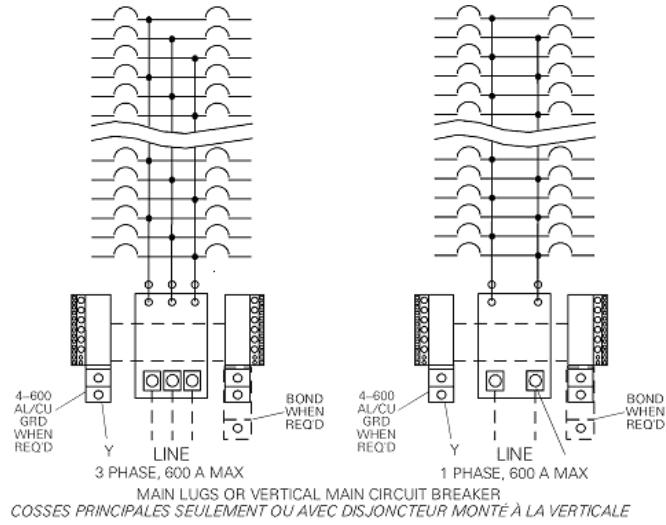

Wiring Diagram / Schéma unifilaire

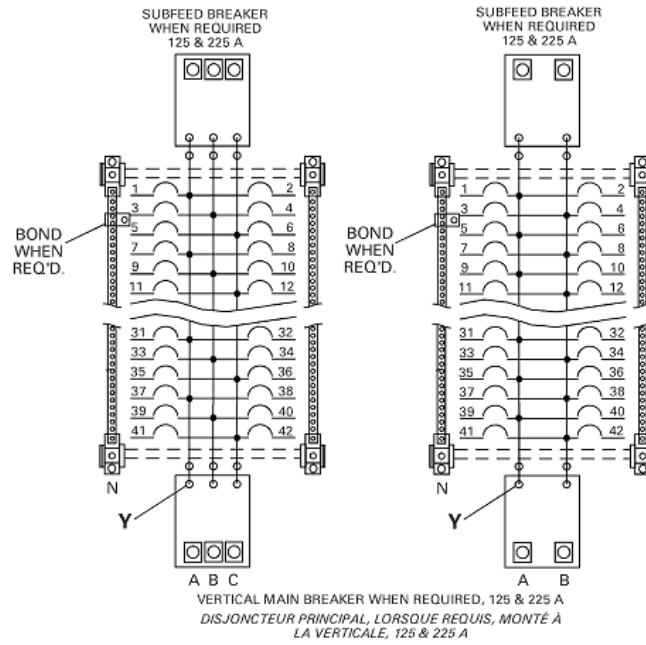

NOTES

NOTES

Ces instructions n'ont pas pour propos de couvrir tous les détails ou variations de l'équipement, ni de fournir des solutions pour tous les imprévus reliés avec l'installation ou l'entretien. Si des informations supplémentaires étaient requises ou s'il survenait un problème particulier lesquels ne sont pas suffisamment couverts selon l'acheteur, ceci devrait être référé à GE Company.

These instructions do not cover all details or variations in equipment nor do they provide for every possible contingency that may be met in connection with installation, operation, or maintenance. Should further information be desired or should particular problems arise that are not covered sufficiently for the purchaser's purposes, the matter should be referred to the GE Company.



GE Consumer & Industrial

General Electric Company
41 Woodford Ave., Plainville, CT 06062
© 2004 General Electric Company

DEH40007 REV08 1108

CIRCUIT DIRECTORY RÉPERTOIRE DES CIRCUITS

1
2
3
4
5
6
7
8
9
10
11
12
13
14
15
16
17
18
19
20
21
22
23
24
25
26
27
28
29
30
31
32
33
34
35
36
37
38
39
40
41
42

CIRCUIT DIRECTORY

RÉPERTOIRE DES CIRCUITS

1	2
3	4
5	6
7	8
9	10
11	12
13	14
15	16
17	18
19	20
21	22
23	24
25	26
27	28
29	30
31	32
33	34
35	36
37	38
39	40
41	42
43	44
45	46
47	48
49	50
51	52
53	54
55	56
57	58
59	60
61	62
63	64
65	66
67	68
69	70
71	72
73	74
75	76
77	78
79	80
81	82
83	84